

## 660 LITRE CONTAINER: A FRESH LOOK AT AN OLD FAVOURITE



**EASY HANDLING  
MAXIMUM SAFETY  
ATTRACTIVE DESIGN**

### Easy handling

- Easy grip handles on all sides
- For easy filling
- For safe manoeuvring
- Compatible with identification and weighing systems



### Reinforced base

- Ensures stability even when fully loaded
- Very stable wheel assemblies
- Reinforced base, front and rear panels for greater stability



### Maximum safety

- User friendly
- Foot pedals on the front wheels lock the bin in position
- Directional locks are ideal for use with towing equipment



# 660 litre Container

## Material

- **Polymer components:**
  - Injection moulded from specially designed HDPE
  - Resistant to decay, frost, heat and chemicals
  - Special UV-stabilisers provide excellent ageing characteristics
- **Corrosion resistant steel components**
- **Noise reduction:**
  - Quiet-running tyres
- **Long service life:**
  - High quality materials
  - Most advanced manufacturing processes
  - Withstands exposure to high mechanical stress levels
- **Recycling:**
  - All container parts are recyclable

## Design

### ADVANTAGES FOR THE USER:

- Easy handling, even with heavy loads
- Easy grip handles on all sides
- Stable and light weight lid
- User-friendly design
- Various wheel assembly configurations for different applications
- Water drainage plug as standard†
- Compatible with identification and weighing systems
- Suitable for all lifting equipment in accordance with EN 840
- Easy to clean due to smooth and rounded internal corners
- Rounded lid profile for improved rainwater dispersal
- Fitted as standard with chip nest in accordance with RAL GZ 951/1
- Reinforced base, front and rear panels for greater stability

## Accessories

- For accessories and special design variations such as lid apertures, locks and towing brackets, please refer to the separate accessories sheet for 4-wheeled containers



SULO MGB Australia Pty Ltd  
123 Wisemans Ferry Road  
Somersby NSW 2250

### Australia

Tel: +61 (0) 2 - 4348 8188  
Fax: +61 (0) 2 - 4348 8128  
Internet: [www.sulo.com.au](http://www.sulo.com.au)  
E-mail: [info@sulo.com.au](mailto:info@sulo.com.au)

SULO – Queensland Office  
11 Argon Street  
Sumner Park QLD 4074

### Australia

Tel: +61 (0) 7 - 3725 5000  
Fax: +61 (0) 7 - 3725 5099

## Quality

- Certified according to DIN EN 840 and RAL GZ 951/1
- Constant quality control through manufacturers laboratory as well as independent institutes

## Dimensions - Weights - Standards

■ Nominal volume:	660 litres
■ Net weight:	43 kg
■ Max. load:	265 kg
■ Permitted total weight:	310 kg

Measurements to be used as a guide only - variations will occur

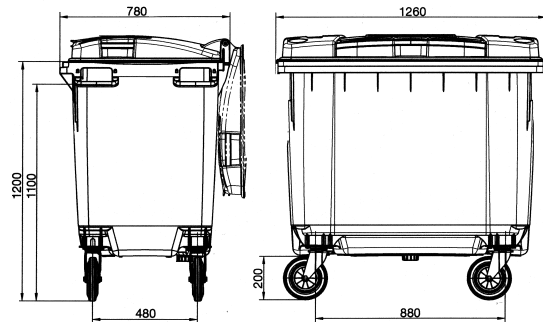

Note: Certification and Quality Marks depicted in this brochure are registered to SULO Umwelttechnik GmbH & Co. KG

## Colours

- Standard colours: green, blue, yellow
- Special colours are available on request
- All additives are cadmium free and environmentally friendly



## Imprints and markings

- Manufacturer, year of manufacture, material
- Nominal volume, max. permitted total weight
- "No hot ashes" symbol
- EN 840, RAL markings
- Individual markings with imprints, hot-foil printing or adhesive labels available on request\*

SULO – Victorian Office  
1950 Hume Hwy  
Campbellfield VIC 3061

### Australia

Tel: +61 (0) 3 - 9357 7320  
Fax: +61 (0) 3 - 9357 7340

SULO - New Zealand  
PO Box 58 962

Greenmount, Manukau City 2141

### New Zealand

Tel: +64 9 - 968 2180  
Fax: +64 9 - 968 2188